

# UMEL-60042-RGBW

## Melbourne 5 Flush In-Ground

### Construction

#### Housing

The luminaire housing is constructed from durable steel for long-term performance, with Trim and top sections made from Marine Grade 316 stainless steel for superior corrosion resistance

#### Memory Retentive - Silicon Gasket

Equipped with a specially designed injection-molded, high-temperature, memory-retentive silicone gasket. This ensures long life and maintains the gasket's exact profile and seal over years of use and compression.

#### Thermal Management

LM6 aluminum is utilized for its exceptional mechanical strength and thermal dissipation properties in both low and high ambient temperatures. Ligman's advanced thermal heat sink, working in conjunction with the LED driver, keeps all components within optimal temperature ranges. This design guarantees extended LED life with less than 10% lumen depreciation at 50,000 hours.

#### Surge Suppression

Each fixture includes a standard 10kV surge suppressor for reliable protection.

#### BUG Rating

B0-U5-G0

#### Hardware

Provided Hardware is Marine grade 316 Stainless steel.

#### Anti Seize Screw Holes

Tapped holes are treated with a special anti-seize compound to prevent thread seizure caused by electrolysis, heat, corrosive atmospheres, and moisture.

#### Crystal Clear Low Iron Glass Lens

Provided with tempered, impact resistant crystal clear low iron glass ensuring no green glass tinge.

#### Optics & LED

Precise optic design provides exceptional light control and precise distribution of light. LED CRI > 80

#### Lumen - Maintenance Life

L80/B10 at 50,000 hours (meaning at least 90% of LEDs maintain 80% of their original flux).

### Discreet, Submersible In-Ground

This premium in-ground uplight is designed for dynamic color-changing applications and precise scene control. Featuring RGBW technology for full-spectrum color mixing and DMX/RDM protocol for professional-grade lighting management, the fixture enables vibrant, customizable environments with real-time programming and remote monitoring. RGBW LEDs deliver rich, saturated colors and high-quality whites for architectural and landscape applications.

DMX/RDM Control allows remote addressing, monitoring, and dynamic scene creation for complex installations.

Supports color transitions, fades, and programmable sequences for creative lighting effects.

The high-density polyethylene in-ground recessing box includes securing lugs on each side to ensure stability during concrete pour. The housing features two shoulders to prevent fixture rotation in drive-over applications. Clear tempered glass, 0.6" thick, supports a maximum load of 5.5 tons, transferring weight to the foundation. Vehicles with pneumatic tires can safely drive over the luminaire at speeds up to 30 mph.

The Melbourne model offers an optional non-slip ADA glass, infused with a specialized coating across the entire lens surface—making it the best non-slip option in the industry.

#### Installation Guidance:

To ensure longevity, provide efficient drainage by placing gravel to a depth of 17 inches and a width of 12 inches beneath and around the housing.

An animated installation video is available on the Ligman website to assist contractors and ensure a problem-free installation.

45w LED (1573 - 2008) Lumens  
IP68 · Suitable For Wet Locations  
IK10 · Impact Resistant (Vandal Resistant)  
Weight 37.5 lbs

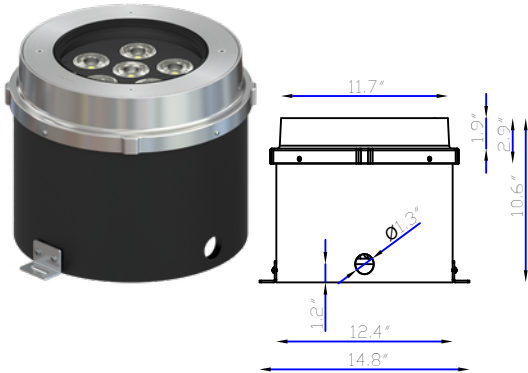
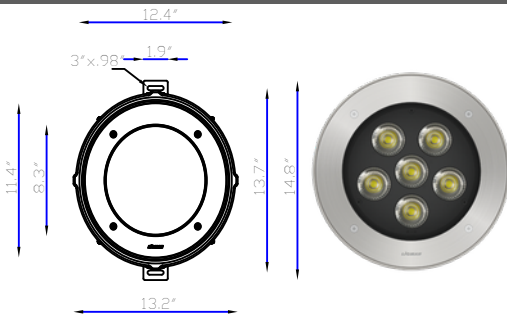

#### Additional Options (Consult Factory For Pricing)

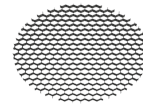

A62521  
Honeycomb Louvre



A62212  
Anti-Slip Glass



A614491  
Glass Suction Cup



# UMEL-60042-RGBW

## Melbourne 5 Flush In-Ground

PROJECT		DATE	
---------	--	------	--

QUANTITY		TYPE		NOTE	
----------	--	------	--	------	--

ORDERING EXAMPLE || UMEL-60042 - 45w - W - RGBW30

UMEL-60042			
LAMP	BEAM	LED COLOR	
45w LED (1573 - 2008) Lumens	N - Narrow Beam 12° W - Wide Beam 37°	RGBW30 - 3200k Warm White RGBW40 - 4000k Neutral White	

--	--	--	--	--	--

### ADDITIONAL OPTIONS

- A62521** - Honeycomb Louvre
- A62212** - Anti-Slip Glass
- A614491** - Glass Suction Cup
- Stick-DE3** - Nicolaudie DMX Controller



## RGBW DMX/RDM Control

RGBW control requires precise communication between lighting fixtures and IP-based systems. To manage Red, Green, Blue, and White diodes effectively, each fixture must be pre-addressed to ensure accurate individual or grouped control.

## Ligman's Engineered Approach

Ligman provides a structured, performance-driven methodology for RGBW system design and deployment.

## Fixture Addressing

Default: Fixtures are factory-programmed with the same DMX address unless otherwise specified.

Issue: Identical addresses cause all fixtures to respond as one—changing colors simultaneously.

Solution: Assign unique DMX addresses to each fixture during programming or via RDM tools to enable independent or grouped control.

## Termination Resistors

To prevent signal interference (crosstalk) between fixtures:

Ligman supplies 120-ohm termination resistors.

Install inside the last fixture or at its J-Box.

Resistor will be factory-installed on most fixtures; some will require on-site installation depending on fixture type.

Connect between DMX+ and DMX- signal lines.

## System Design Guidelines

Fixture Count:

3 or More Fixtures: A terminating resistor must be installed at the end of the run.

5 or More Fixtures: Ligman may request additional layout details to validate system integrity.

## Dual DMX Address Fixtures:

Fixtures with dual DMX addresses require more DMX channels, reducing the number of fixtures per run. (Refer to technical drawings for specifics.)

## Maximum Distance Without Booster:

984 ft (300 m) from the controller.

Beyond this limit: DMX/RDM splitters or boosters are required.

## Custom Layouts

For non-standard RGBW configurations, Ligman requires:

Fixture quantity per run

Distance between fixtures

Total cable length from controller to last fixture

## This ensures:

Reliable DMX signal transmission

Proper use of termination resistors and splitters

Compliance with fixture and distance limitations

Single Fixture Connection  
Or  
Final Fixture Connection

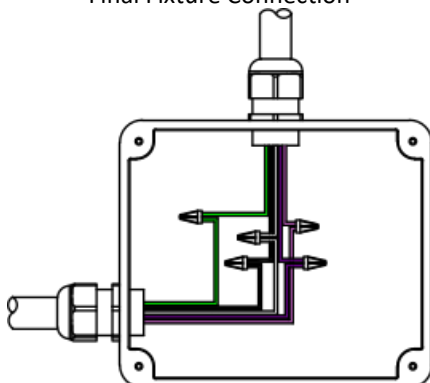

### DETAIL WIRE COLORS FOR 5-WIRE CABLE

GREEN-----GROUND  
BLACK-----120/277 HOT  
WHITE-----NEUTRAL  
PURPLE-----DMX +  
PINK-----DMX -

Looping to Multiple Fixtures  
Example Fixture#1,2,3,4,ect.

